

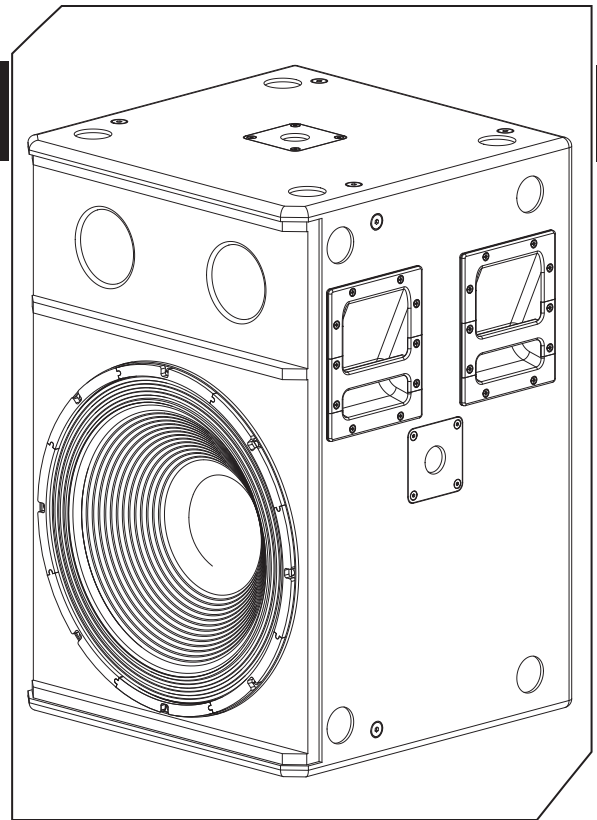

# 118Sub-W™

## 18" HIGH-OUTPUT LOW FREQUENCY SUB WOOFER SOUND REINFORCEMENT SYSTEM

ONE SYSTEMS™



The 118Sub-W™ is a single 18" high output low frequency sub woofer sound reinforcement system. The system utilizes a rectangular enclosure geometry. This geometry provides increased low frequency response due to its larger internal volume, as compared to a conventional trapezoidal enclosure. This design is intended for applications where the 118Sub-W is used in conjunction with the 115TW™ or 115RW™ ONE SYSTEMS™ enclosures.

The 118Sub-W may be used in outdoor installations as well as indoor applications where high output and accuracy are required. The unique design of the 18 inch 18I/O woofer provides an excellent combination of high sound pressure levels and low distortion

The ONE SYSTEMS 118Sub-W features an 18mm birch rectangular plywood enclosure that utilizes stainless steel internal structural supports to enable a variety of suspension points.

The grill is a 3 layer "rain shield" design that will minimize direct rain contact with the systems transducers. All internal and external metal hardware, as well as the grill, are stainless steel. The enclosure and grill design are rated to IEC 529 IP45 (solid object penetration to 1 mm (0.04 inches) and water jets from any direction). The enclosures and components are also rated to Mil Spec 810

The input section consists of both 4 pin Neutrik® Speakons® as well as a

stainless steel hardware barrier strip. A weather cover is provided with an integral gland nut connector for outdoor applications. In the outdoor configuration connections are made thru the 4 position barrier strip.

The gland nut is weather proof and is rated NEMA 6P (IP68). The connector will accommodate cable outside diameters from 7mm to 12mm (0.236" to 0.472"). The maximum diameter will accommodate most 2 conductor AWG 12 cable assemblies.

The low frequency design is patent pending. The 18 inch 18I/O woofer (Inside Only) utilizes a unique voice coil wind on the inside of the voice coil support structure. This design allows for both high magnetic system displacement as well as increased thermal transfer. This results in reduced power compression and higher reliability.

Because the ONE SYSTEMS 118Sub-W is designed for permanent installation applications a variety of rigging and suspension options are available. The 118SubW has 20 M10 mounting points.

An M10 forged shoulder eye bolt kit is available for all M10 suspension points.

The system may be used with 115TW enclosure in both simple and "T" planar arrays using the FLY-112TW or FLY-115TW-T planar array kits.

### FEATURES AND BENEFITS

- Weather Resistant 18" low frequency system.
- Rectangular Enclosure Geometry for Optimized Bass
- Optimized for use with the 115TW™ and 215RW™
- 18 inch 18I/O ONE SYSTEMS woofers
- Patent Pending large voice coil low frequency transducer.
- Multiple M10 flying points.
- Available Array brackets Planar arrays
- Gland Nut and Speakon inputs  
(Weather cover for Gland nut installations).

### SPECIFICATIONS

Frequency Response:	40Hz – 150Hz
Coverage Pattern:	Essentially omnidirectional
Crossover Frequency: Low pass 24dB / octave	Recommended 80Hz (150z max)
Inputs:	4 position barrier or 2 each 4 pin Speakon
System Sensitivity: (1watt-1meter)	95dB
Power Handling:	800 watts Continuous 1600 watts Program 3200 watts Peak*
* All power handling ratings are amplifier headroom dependent	
Nominal Impedance:	8 ohms

Speakon® is a registered trademark of Neutrik®



ONE SYSTEMS™

# 118 Sub-W™

## SYSTEM SPECIFICS

Low Frequency:	ONE SYSTEMS 18 I/O
High Frequency:	N/A
System Tunings (Bi-amp mode):	<a href="http://www.ONESYSTEMS.com">www.ONESYSTEMS.com</a>
EASE 4.0 data	<a href="http://www.ONESYSTEMS.com">www.ONESYSTEMS.com</a>
Suspension/Mounting points:	20 each M10
Weather Performance:	IEC 529 IP 45 Mil Spec 810
Dimensions (H x W x D):	793.4mm x 535mm x 527mm (31.24 in x 21.06 in x 20.75 in)
Net Weight:	42.3 kg (93.3 lb)
Optional Accessories:	FLY-115TW FLY-115TW-T M10 Forged Shoulder Eye Bolt
Additional Supporting Systems:	115TW 115RW 212IM System Supervisor™ (4 in x 8 out 24bit dsp processor) 2.4 En™ 2400 Watt Power Amp

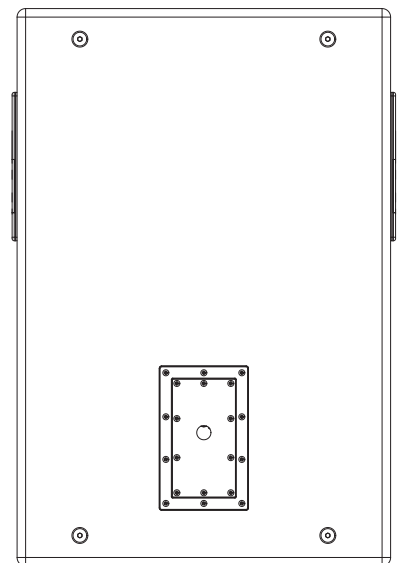
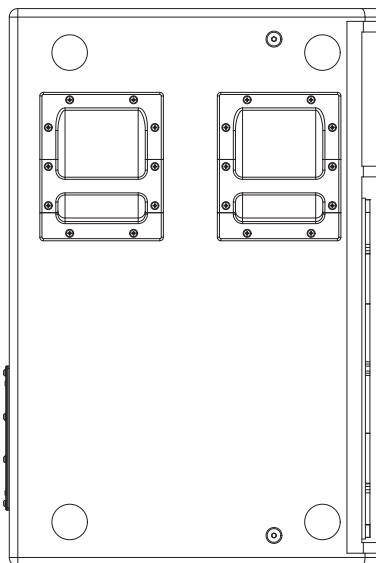
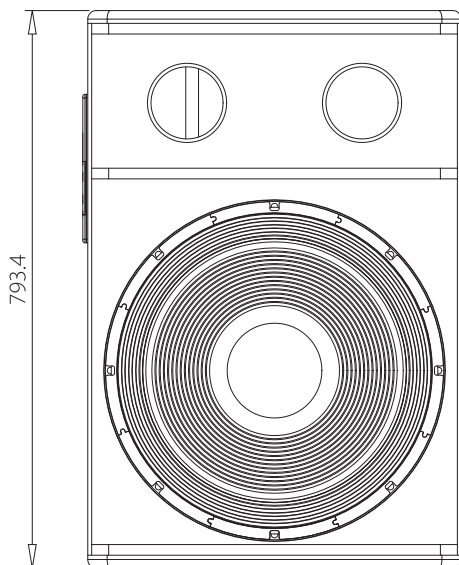
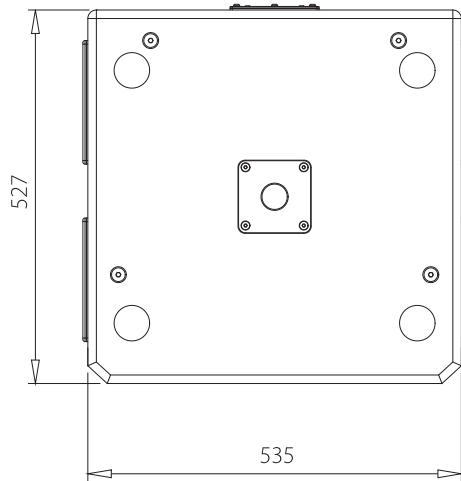

ONE SYSTEMS™

ONE SYSTEMS USA, Inc • 15455 Dallas Parkway, Suite 600 • Dallas, Texas 75001  
ONE SYSTEMS Group- European Division • Mittelsmoorer Strasse 12 • 28879 Grasberg Germany  
ONE SYSTEMS Global Co. Ltd. • 87/114 Modern Town 15th Floor • Sukhumvit 63 Ekkamai Soi 3  
Klongtoey, Bangkok 10110 Thailand