

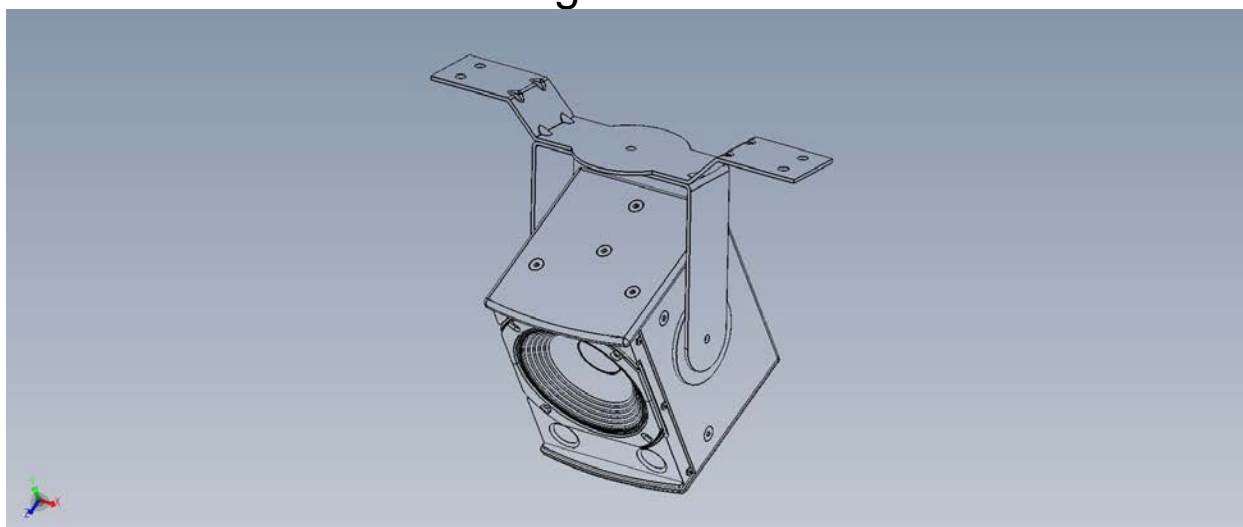

# Pan and Tilt Bracket Installation Guide PTB-8NP

August 2013



PTB-8NP with OPA-8NP enclosure

The On Point Audio PTB-8NP is an easy to install and flexible system designed to allow the OPA-8NP loudspeaker enclosure to be mounted on a ceiling or other structural flat overhead surfaces. The only products approved for use with the PTB-8NP is the OPA-8NP enclosure. **NO** other products may be substituted!

**WARNING:** The PTB-8NP is **NOT** designed for wall mount. The PTB-8NP is designed for ceiling mount **ONLY!**

**NOTE:** The OPA-8NP enclosure and PTB-8NP are for **INDOOR** use only! **DO NOT USE IN OUTDOOR ENVIRONMENTS!**

The following actions **MUST** be performed **PRIOR** to beginning the installation of the PTB-8NP and OPA-8NP:

1. This installation guide must be completely read and understood.
2. The instruction manual “Rigging and Suspension of On Point Audio Products” must be read and understood. (This instruction manual is available along with other technical papers at [www.onpointaudio.com](http://www.onpointaudio.com))
3. The structure of the mating surface **MUST** be capable of supporting the combined weight of the PTB-8NP bracket, the OPA-8NP loudspeaker and all associated rigging. It must satisfy the required safety factors specified by local and national codes, as well as safe rigging practices. The PTB-8NP weighs 2.3kg (5.1 lbs). The OPA-8NP enclosure weighs 6.8kg (15 lbs).
4. The PTB-8NP pan and tilt bracket should be installed only by someone experienced in the overhead suspension of items. They should be familiar with applicable local/national codes governing the installation of these types of products and those governing the attachment of these types of products to specific structures.
5. The PTB-8NP is designed for ceiling mount **ONLY! DO NOT WALL MOUNT!**

**CAUTION:** The PTB-8NP bracket and OPA-8NP enclosures are designed for **INDOOR** use and installation **ONLY! DO NOT INSTALL IN OUTDOOR ENVIRONMENTS!**

## INSTALLATION

The PTB-8NP consists of two parts: the ceiling bracket and the loudspeaker bracket. The ceiling bracket and loudspeaker bracket are shown below in Figure 1.

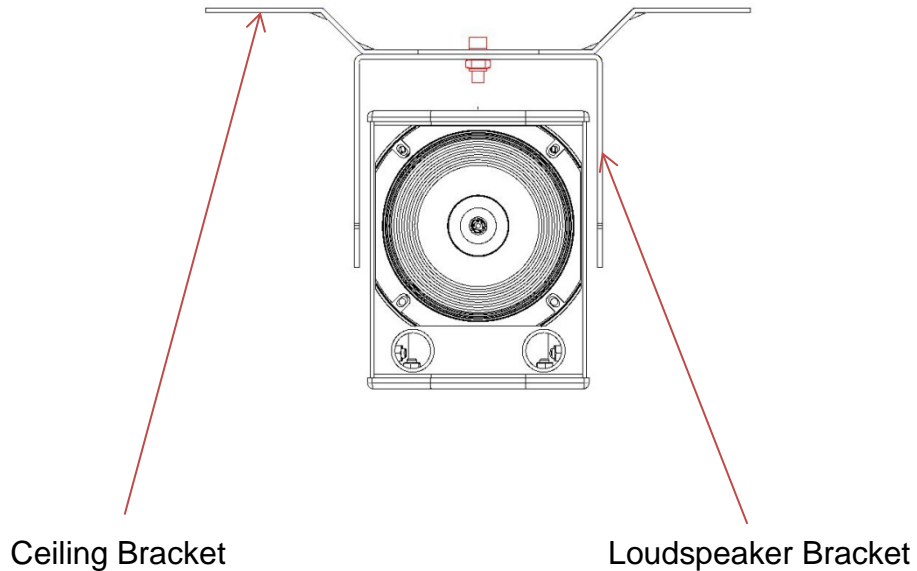

Figure 1

The ceiling bracket and loudspeaker bracket are joined together by a hex head M10 bolt and nylon insert M10 nut assembly. **DO NOT** remove this M10 bolt and nut assembly. The combination of the ceiling bracket and loudspeaker bracket should stay assembled during mounting to the ceiling.

The ceiling bracket is mounted to a ceiling surface using the four (4) holes shown in red in Figure 2 (below).

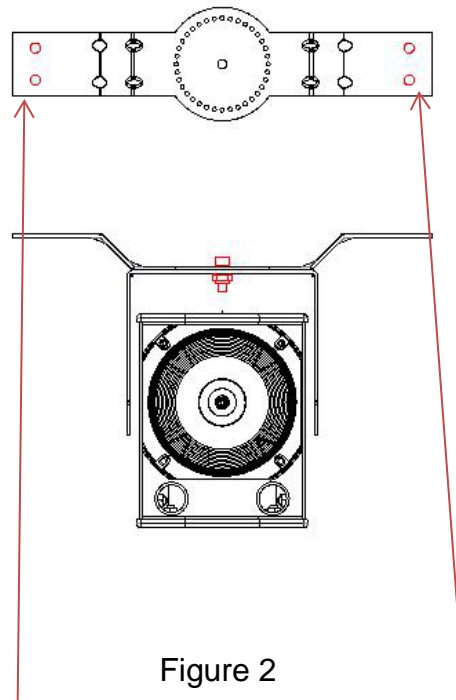

Figure 2

Figure 2 (above) shows the four (4) mounting locations to join the ceiling bracket to a ceiling surface. These four mounting locations are designed to allow M10 diameter hardware. The ceiling bracket section should now be mounted to the ceiling surface.

**IT IS NECESSARY TO USE ALL FOUR (4) MOUNTING HOLES TO ENSURE A SAFE AND SECURE MATE TO THE ASSOCIATED SURFACE!**

All fasteners associated with the mounting of the PTB-8NP ceiling bracket to the mating surface are the responsibility of others. The design and structural capacity of mating surfaces (ceilings) vary greatly and specific fasteners are designed for use with specific mating surfaces. On Point Audio does not recommend any mating fasteners and strongly urges the installer to consult with one experienced in suspension of products from the specific mating surfaces and the appropriate choice of fasteners for those specific surfaces.

The ceiling bracket section should be secured firmly to the mating surface using the appropriate fastening system. The fastening system should be determined by the structure of the mating surface.

**IT IS CRITICAL THAT THE MATING SURFACE BE CAPABLE OF SUPPORTING THE LOAD OF THE PTB-8NP BRACKET AND THE OPA-8NP LOUDSPEAKER AND ALL SUSPENSION HARDWARE, AS WELL AS PROVIDING THE PROPER SAFETY FACTORS. DO NOT ATTEMPT TO SUSPEND THE BRACKET AND LOUDSPEAKER UNTIL THE STRUCTURAL CHARACTERISTICS OF THE MATING SURFACE ARE UNDERSTOOD. DO NOT INSTALL THE PTB-8NP BRACKET AND OPA-8NP**

LOUDSPEAKER IF THE MATING SURFACE IS NOT CAPABLE OF SUPPORTING THE ENTIRE ASSEMBLY WEIGHT, AS WELL AS PROVIDING THE REQUIRED SAFETY FACTORS!

After the PTB-8NP ceiling section of the bracket is securely mounted to the ceiling, the OPA-8NP loudspeaker enclosure should be attached to the loudspeaker bracket using the fasteners supplied. **(DO NOT SUBSTITUTE FASTENERS)**

**NOTE:** There are 2 each M8 bolts supplied in the mounting kit of the PTB-8NP.

**USE EXTREME CAUTION!** The loudspeaker is heavy and it is likely that the desired mounting location is high in the air. This process should *never* be attempted by a single person.

**TWO OR MORE PEOPLE ARE REQUIRED TO MOUNT THE LOUDSPEAKER ENCLOSURE TO THE PTB-8NP bracket.** Safety harnesses should always be worn when working from an elevated platform.

Insure that the two rubber spacers are installed between the side walls of the enclosure and the loudspeaker bracket section of the PTB-8NP as shown below in Figure 3.

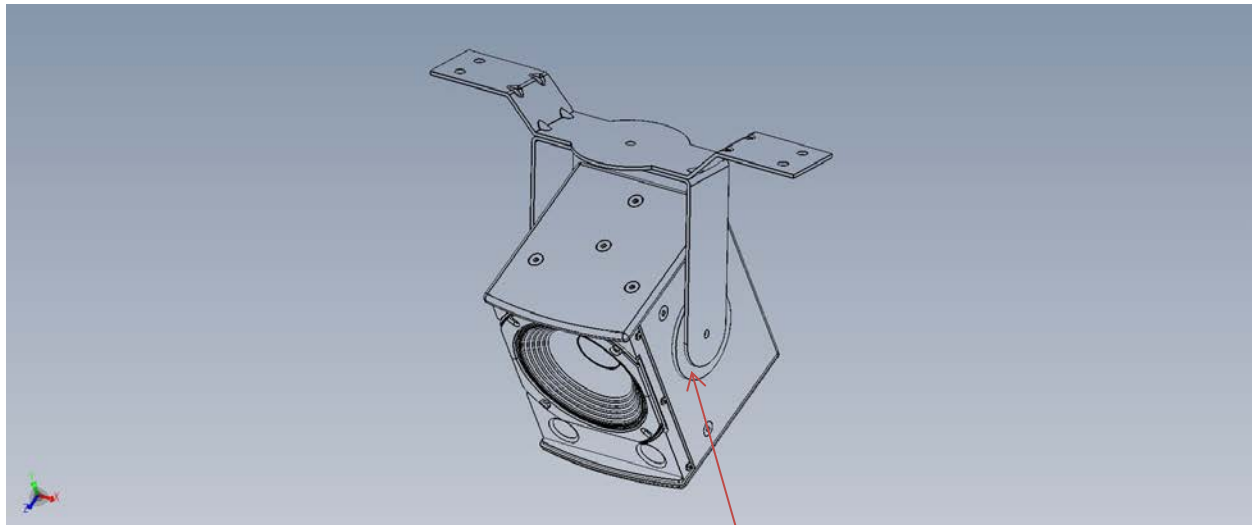

Figure 3

Install the two large rubber spacers (100mm diameter) on each side of the enclosure between the enclosure and the loudspeaker bracket section as shown.

Then install the M8x40mm bolts (one on each side of the loudspeaker bracket) making sure to use both the supplied M8 flat washers AND lock washers. **BOTH THE FLAT WASHERS AND LOCK WASHERS MUST BE USED!** Figure 4 (Below) shows is an image of the PRB-8NP showing the rubber spacer, loudspeaker bracket, flat washer,

lock washer and M8 bolt. Only the right side is shown below in Figure 4, but **BOTH** sides must utilize the 100mm diameter rubber washer!

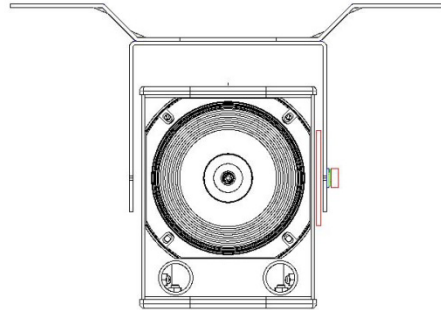

Figure 4

Figure 5 is a close up of the right side of the assembly shown in Figure 4. (Right side shown for clarity, left side is identical). The washer, lock washer, rubber washer and M8 bolt must be used on **BOTH** sides of the loudspeaker bracket to fix the OPA-8NP to the PTB-8NP pan and tilt bracket!

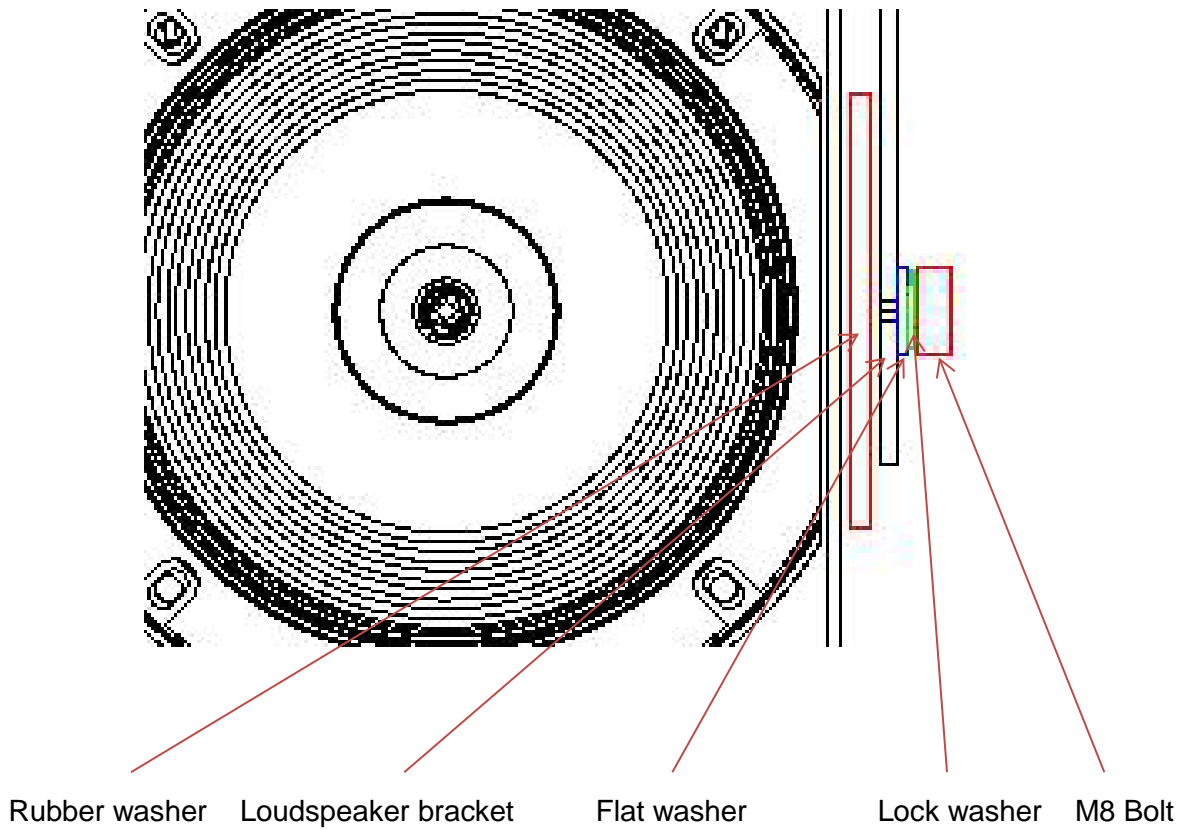
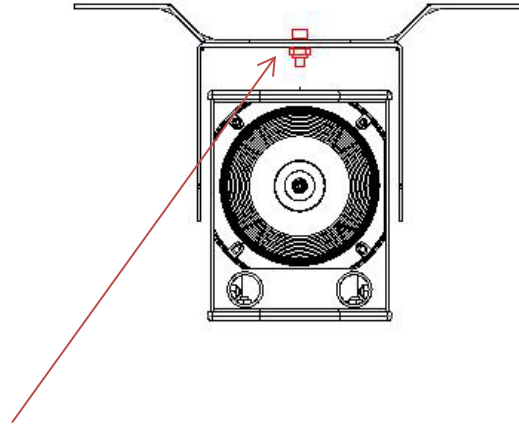

Figure 5

Set the desired tilt angle of the OPA-8NP loudspeaker in the loudspeaker bracket and then securely tighten the two (2) M8 bolts against the sides of the loudspeaker bracket.

Now the pan angle may be set. The PTB-8NP allows pan angle aiming in 10 degree increments thru a full 360 degree circle. Once the desired pan angle is set the M10 bolt and nylon insert nut that secure the ceiling bracket to the loudspeaker bracket may be tightened.



Tighten the M10 hex head bolt and nylon insert nut once the pan angle has been set.

**NOTE:** Secondary safety cables are **STRONGLY** recommended and should be secured to a structural point **NOT** associated with the PTB-8NP bracket or loudspeaker!

**The products referenced in this manual are in conformity with the following standards or other normative documents: Machinery Directive 2006/42/EC**

©On Point Audio 2013      Nashville, TN U.S.A.  
©One Systems, Inc. 2014

[www.onpointaudio.com](http://www.onpointaudio.com)  
[www.onesystems.com](http://www.onesystems.com)