



**ONE SYSTEMS®**

# 106IM™

## Direct Weather High Performance Loudspeaker System

The One Systems 106IM was designed to provide high acoustic output and IP45 rated direct weather performance in high performance acoustic spaces. The 106IM is a very high performance back ground/fore ground system designed for use in all weather conditions.

The design is very unique for a sound reinforcement system of this size in that it features a true compression driver coupled to a constant directivity high frequency horn. The rated coverage pattern of the compression driver/horn system is 90 degrees horizontal by 40 degrees vertical. The high efficiency compression driver and advanced crossover design provide for very high power handling and system reliability without the need for performance degrading passive protection devices typically found in loudspeaker systems of this class. The 6" (152mm) high performance woofer also presents a unique design feature that provides both extended bandwidth response as well as superior low frequency power handling. The 6" woofer features a very large diameter coil design that offers excellent system reliability without the need for addition performance degrading protection devices. The combination of high efficiency horn loaded compression driver and very large format voice coil design in the woofer yield superior system intelligibility and vocal range integrity.

The enclosure is an injection molded design featuring a high weatherability material designed for use in extreme environments and offers a high degree of UV protection for use in direct sunlight. The enclosure has 6 mounting points, two each M6 (one top and one bottom) that are used for the 106IM-U "U" bracket (supplied). The 106IM may also be mounted using four each M5 for the optional PT-10 pan and tilt bracket. All mounting points are stainless steel. The grill assembly is a 3 layer design optimized for acoustic transparency and weather protection from both wind blown particles and water. The input section features a weather cover with an integral gland nut that is rated to IP68. System inputs are via a four position barrier strip.

The 106IM is available in both an 8 ohm impedance as well as both 70.7 volt and 100 volt versions. The transformer versions feature a 50 watt wide bandwidth transformer with 50 watt, 25 watt and 12.5 watt taps that are accessible thru the four position barrier strip.

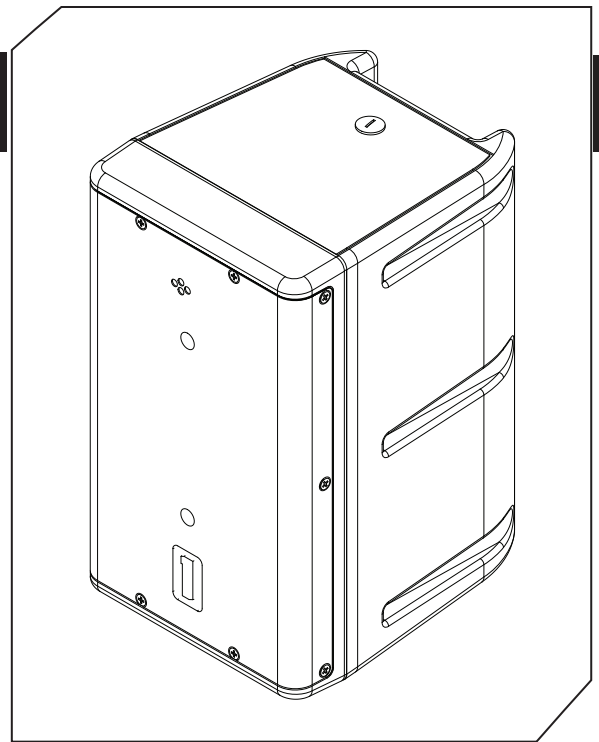

### FEATURES AND BENEFITS

- Direct weather 6" two way system
- High Performance Foreground/Background
- Direct Weather High Performance
- Stainless Steel Rigging and Grill
- IP 45 Rated
- Large Format voice coil designs
- U Bracket Included
- Available Pan and Tilt

### SPECIFICATIONS

Frequency Response	80Hz-16kHz
Coverage Pattern	90H x 40V
Passive Crossover	2000HZ
System Sensitivity (1 watt 1 meter)	89dB
Power Handling	100 watts Continuous 200 watts Program 400 watts Peak
Nominal Impedance	8 ohms
Weather Performance	IP45
Net Weight	6.0kg (13.2lbs)
Transformer Version	6.5kg (14.3lbs)
Dimensions (H x W x D)	312 mm x 185 mm x 217.1 mm 12.3 in x 7.3 in x 8.5 in

**ONE SYSTEMS™**



# 106IM™

Direct Weather High Performance  
Loudspeaker System

ONESYSTEMS®

