

208CIM™

COMPACT TWO ELEMENT VERTICAL ARRAY LOUDSPEAKER SYSTEM

ONE SYSTEMS™

The 208CIM is a very compact two element vertical array (LF and Mid Bass) high output loudspeaker system. The 208CIM was designed to produce very high sound pressure level vocal range content with very high intelligibility. The 208CIM is a very compact dual 8 inch system that uses a single coaxially mounted high frequency horn to reproduce higher frequency vocal information. The vocal fundamentals are reproduced by a 2 element direct radiator design that does not suffer from the traditional colorations found in horn systems. The 208CIM is basically a compact 2 element 8 inch vertical array where the top 8" incorporates a coaxially mounted large format compression driver.

The 208CIM may be used in direct weather outdoor installations as well as indoor applications where high vocal intelligibility and accuracy are required. Like all ONE SYSTEMS products, the 208CIM was designed to not only offer excellent full range fidelity but superior vocal reproduction and intelligibility as well. The unique design of this system allows both extended range directional control through the vocal fundamental range and twice the acoustic output compared to conventional 8 inch two way designs.

The 208CIM system offers a complete selection of array and flying/suspension hardware. The enclosure is also available with a 75 watt 3 tap line matching transformer. The 208CIM-100 or 208CIM-70 may be ordered with either a 100V or 70.7V primary.

The 208CIM is optimized for outdoor applications such as football stadiums, baseball stadiums, race tracks and other sports venues where permanent installation is required as well as a direct weather exposure. The high SPL capability of the 208CIM allows it to be used in many ap-

plications where a traditional 12 inch two way system would be used. The system is particularly suited for compact but high level announcements and general vocal range reproduction. The system is equally suited for general purpose indoor applications in multipurpose rooms, indoor sports venues and general performance or vocal intensive applications.

The 208CIM enclosure is a copolymer optimized for high UV exposure and long life in harsh environments. All internal and external rigging and suspension hardware, as well as the metal grill are stainless steel or high strength aluminum.

The grill is a 3 layer "rain shield" design that will minimize direct rain contact with the systems transducers. The unique vent design also allows for easy moisture drainage from the interior of the enclosure. The enclosure and grill design are rated to IEC 529 IP45 (solid object penetration to 1 mm (0.04 inches) and water jets from any direction). The enclosures and components are also rated to Mil Spec 810

The input section consists of both 4 pin Neutrik Speakons as well as a stainless steel hardware barrier strip. A weather cover is provided with an integral gland nut connector for outdoor applications. In the outdoor configuration connections are made thru the 4 position barrier strip.

The gland nut is weather proof and is rated NEMA 6P (IP68). The connector will accommodate cable outside diameters from 7mm to 12mm (0.236" to 0.472"). The maximum diameter will accommodate most 2 conductor AWG 12 cable assemblies.

The basic configuration of the 208CIM is a 2 element vertical arrangement of ONE SYSTEMS 8" direct radiator full range loudspeakers. The top 8 inch has a state of the art "thru the pole piece" coaxially oriented high frequency horn and driver

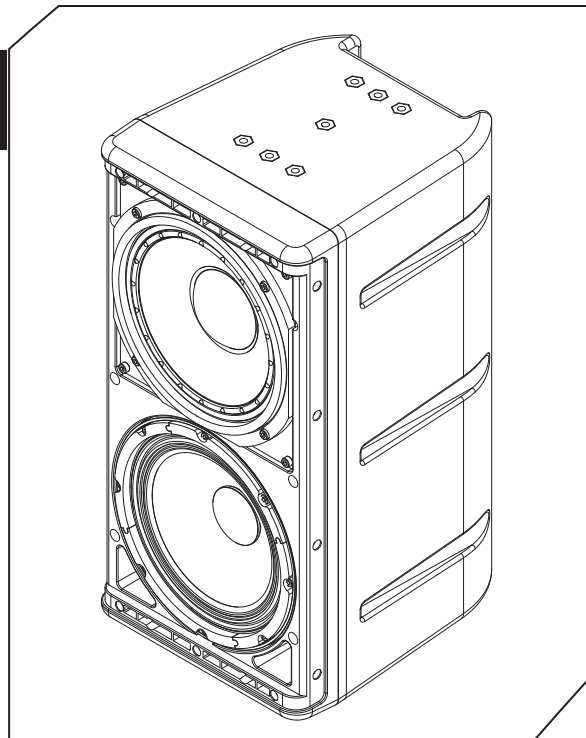

FEATURES AND BENEFITS

- Very High SPL Vocal System.
- Direct weather two element vertical array two-way system.
- Optimized for high intelligibility and vocal articulation.
- Multiple M8 flying points.
- Available Pan and Tilt, and "U" brackets.
- Gland nut and Speakon inputs (Weather cover for Gland nut installations).
- Optional version (208CIM-100 & 208CIM-70) with 75 watt 3 tap 100V or 70V line matching transformer

SPECIFICATIONS

Frequency Response:	65Hz – 16kHz
Coverage Pattern:	70 degrees conical
Passive Crossover Frequency:	2000 Hz
(externally switchable Bi-amp)	
Inputs:	4 position barrier or 2 each 4 pin Speakon
System Sensitivity:	96dB
(1watt-1meter)	
Power Handling:	400 watts Continuous 800 watts Program 1200 watts Peak*
* All power handling ratings are amplifier headroom dependent	
Nominal Impedance:	4 ohms



208CIM™

ONE SYSTEMS

combination. The high frequency radiation pattern is fixed and not rotatable but optimized for medium throw applications.

Because the ONE SYSTEMS 208CIM is designed for permanent installation applications a variety of rigging and suspension options are available. The 208CIM has multiple M8 mounting points. An M8 forged shoulder eye bolt kit is available for all M8 suspension points

The 208CIM may be suspended as a single unit using the ONE SYSTEMS "U" bracket in either a vertical or horizontal configuration. The "U" bracket is a ONE SYSTEMS 108IM-U

The 208CIM may be mounted in selected installations (when permitted by local codes and appropriate substrates) using either a ONE SYSTEMS pan and tilt bracket (PT-35) bracket.

The 208CIM is also available in a line matching transformer version in both 100V and 70.7V ratings. The internal transformer is a 75 watt 3 tap (75 watts, 37.5 watts, and 18.75 watts). This is the 208CIM-100 or 208CIM-70 version.

SYSTEM SPECIFICS

Low Frequency:	ONE SYSTEMS 8, 8C
High Frequency:	Medium format compression driver
EASE 4.0 data	www.ONESYSTEMS.com
Suspension/Mounting points:	M8
Weather Performance:	IEC 529 IP 45 Mil Spec 810
Dimensions (H x W x D):	483.84mm x 243.2mm x 270.77mm (19.05 in x 9.56 in x 10.66in)
Net Weight:	18 kg (39.7 lb) 19.5 kg (43 lb) transformer ver.
Optional Accessories:	108IM-U "U" bracket kit PT-35 Pan and Tilt M8 Forged Shoulder Eye Bolt

