

OPA-8NP

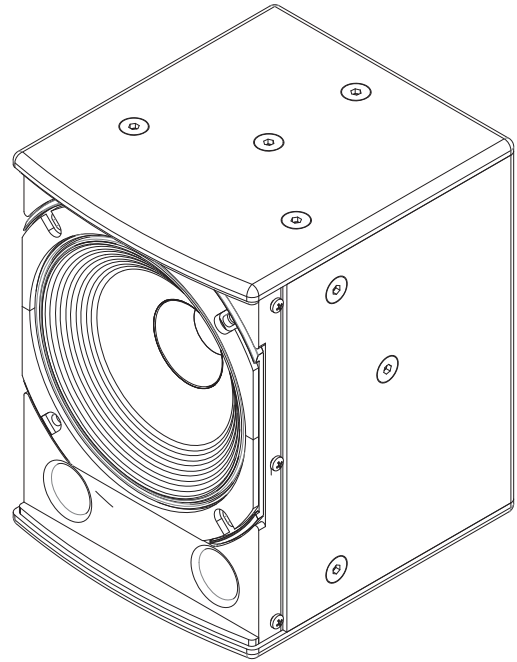

The On Point Audio OPA-8NP is a high-performance, narrow-profile coaxial 8 inch (203mm) two-way loudspeaker system. The OPA-8NP has been designed to provide superior intelligibility and fidelity for indoor permanent installations. The OPA-8NP features a 90-degree conical high-frequency horn radiation pattern. This pattern allows for wide coverage in near field applications. The OPA-8NP was designed to not only offer excellent fidelity, but also provides superior vocal reproduction and intelligibility too. The system consists of a single coaxial 8” woofer and pure titanium true compression driver. The high-frequency driver is a small format design. The OPA-8NP is an ideal design for fixed installations, where excellent bandwidth and controlled time domain response are specified. The system design allows for superior intelligibility and articulation.

The OPA-8NP system offers a complete selection of array and flying/suspension hardware. The enclosure offers multiple M8 rigging points and may be flown using forged shoulder eyebolts, a U-bracket, or a unique pan and tilt bracket that was designed exclusively for the OPA-8NP.

The OPA-8NP enclosure has high-quality plywood construction and features On Point Audio’s Power Coat polyurea finish. The 8-inch woofer is an On Point Audio “narrow profile” design that provides a large cross sectional area radiating surface in a small profile. The input section consists of a 4-pin barrier strip. The small size and high output performance make the OPA-8NP an excellent choice for high-performance foreground music and announcement systems.

FEATURES

- » High-Output/High-Intelligibility two-way coaxial system.
- » Very small format enclosure with excellent range of aiming
- » Optimized for high-intelligibility and vocal articulation.
- » Conical radiation pattern optimized for wide coverage
- » Pure titanium compression driver
- » Multiple M8 flying points
- » Available Pan and Tilt and U-bracket

SPECIFICATIONS

Frequency Response:	80Hz – 16kHz
Coverage Pattern:	90 degrees conical
Passive Crossover Frequency:	1600Hz
Inputs:	4-position barrier
System Sensitivity (1watt-1meter):	91dB
Power Handling:	150 watts Continuous 300 watts Program 600 watts Peak*

* NOTE: all system power handling ratings are amplifier headroom dependent

Nominal Impedance:	8 ohms
System Components:	NP8-CXFF Coax
Suspension/Mounting points:	M8
Dimensions (H x W x D):	242.5 x 183 x 208mm (9.54 in x 7.2 in x 8.2 in)
Net Weight:	6.8 kg (15 lb)
Optional Accessories	OPA-8-NP-U U-bracket kit M8 Eye Bolt Kit-W PTB-8NP pan and tilt bracket

OPA-8NP

