



## **POLE MOUNT SYSTEM EX INSTALLATION**

The Pole Mount System EX is an easy to install and flexible system designed to allow ONE SYSTEMS® loudspeaker systems to be mounted to pole structures. The only products approved for use with the Pole Mount System EX are the 212IM, 312CIM and the Cross Field Array.

**NO OTHER LOUDSPEAKERS SHOULD BE SUBSTITUTED!**

The following actions **MUST** be performed **PRIOR** to beginning the installation of the Pole Mount System EX:

1. This installation guide must be completely read and understood
2. The instruction manual “Rigging and Suspension of ONE SYSTEMS Products” must be read and understood. (This instruction manual is available at [www.ONESYSTEMS.com](http://www.ONESYSTEMS.com) in the “Education section of the web site.
3. The manufacturer of the pole **MUST** be consulted to verify the applicability of the Pole Mount System EX and ONE SYSTEMS loudspeaker to the specific pole
4. The Pole Mount System EX loudspeaker should be installed only by one experienced in the overhead suspension of items and familiar with the applicable local and national codes governing installation of these products and also governing the attachment of these products to the specific pole structure.

**CAUTION:** All structures outdoors are subjected to wind forces. These forces must be considered when suspending any product outdoors. It is necessary to know the “Effective Projected Area” (EPA) of the loudspeaker prior to installation of the loudspeaker and Pole Mount System EX. This data must be supplied to the pole manufacturer in order to determine safe operation conditions for the loudspeaker and Pole Mount System EX

when mounted to a specific pole. See Appendix 1 of this installation manual for effective projected areas for each enclosure rated for use with the Pole Mount System EX.

## INSTALLATION

The Pole Mount System EX consists of three parts: the pole bracket, the loudspeaker bracket, and the Safety Link. The pole bracket is shown in Figure 1. The bracket shown in figure 1 is designed for pole diameters of 8 inches (203.2mm) to 20 inches (508mm). The unique “self adjusting” hinge design of the pole mount will adjust to this specified range of pole diameters. Pole diameters smaller than 8 inches must not be used.

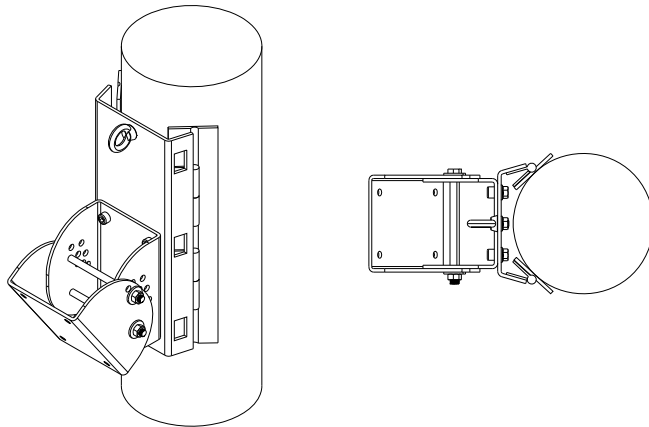

Figure 1.

Figure 1 represents the isometric and top views of the pole bracket, including the loudspeaker bracket section. The loudspeaker bracket is shown separately in Figure 2.

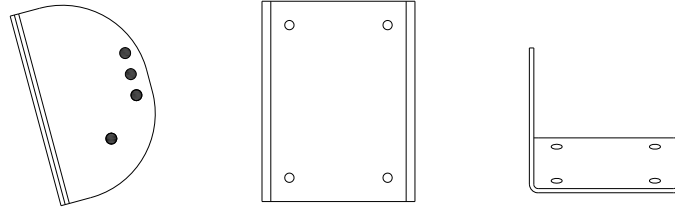

Figure 2.

Figure 3 is a representation of the Safety Link assembly. This assembly **MUST** be used whenever the Pole Mount System EX is being used.

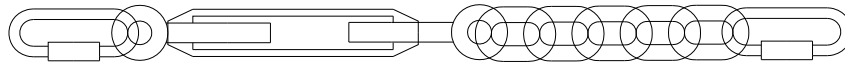

Figure 3

1. Mount the pole mount section (see figure 1) of the bracket to the pole at the desired height on the pole. The bracket is mounted to the pole using BAND-IT stainless steel bands. **DO NOT SUSTITUTE** bands of other material or other widths! There are four locations on the pole bracket for bands. **ALL FOUR LOCATIONS MUST BE USED.** Figure 4 illustrates the locations for the stainless steel band clamps.

It is **REQUIRED** that each of the four bands be **DOUBLE** wrapped. Double wrapping will insure a strong and secure mounting of the bracket to the pole. The stainless steel banding materials should be as follows:

- BAND-IT # C206R9 stainless steel bands
- BAND-IT # C25699 buckles
- BAND-IT # C00169 tensioning tool

The stainless steel band is Type 201SS 0.030 inches (0.762mm) thick and 0.750 inches (19mm) wide.

**WARNING:** Do NOT substitute banding materials or banding dimensions.

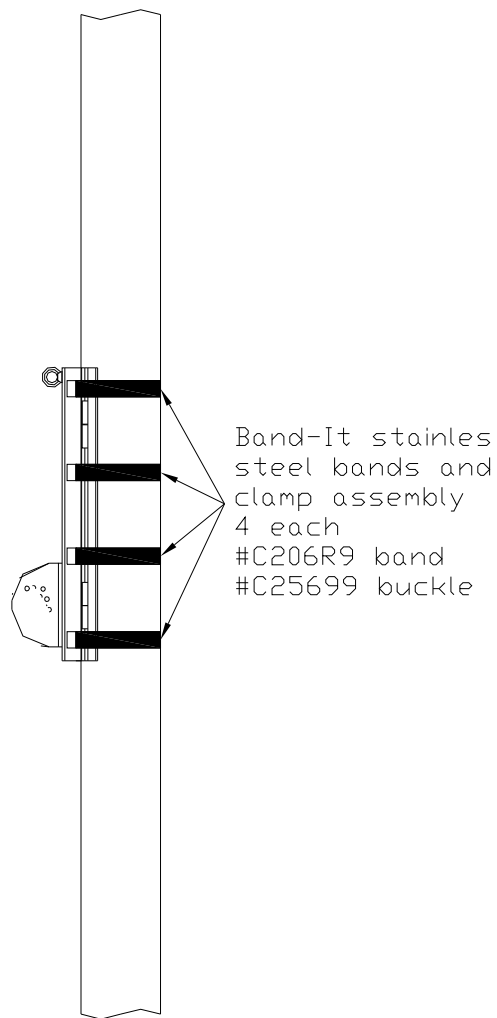

Figure 4.

Installation instructions from BAND-IT should be followed exactly. Operating instructions are supplied with the tensioning tool. (All BAND-IT parts and tools purchased separately. These parts and tools are not supplied by ONE SYSTEMS).

The stainless steel banding material, buckles, and tensioning tools are available from the following locations (or through distributors recommended by these locations):

BAND-IT IDEX, Inc.  
4799 Dahlia St.  
Denver Colorado 80216  
USA  
1-800-525-0758

FELIX PONCE  
Calle Ignacio Zaragonza No. 8  
Colonia Ahuehuetes Atizapan 52953  
Edo. de Mexico  
(52) 555825 8502

BAND-IT Company Limited  
Speedwell Industrial Estate  
Stavely, Nr. Chesterfield  
Derbyshire, S43 3PF England  
Home Sales (44) 1246-479479  
Export Sales (44) 1246 479480

BAND-IT Clamps (ASIA) Pte. Ltd.  
11 Second Chin Bee Road  
Singapore 618777  
65-62658853

BAND-IT Shanghai Sales Office  
207 room  
Wanbao International Business Centre  
660# Xinhua Road  
Shanghai, China 200052  
021-62826348-308

2. Next, the loudspeaker bracket should be mounted to the loudspeaker (ONE SYSTEMS 212IM, 312CIM or Cross Field Array only) using the supplied M10 stainless steel bolts and internal tooth lock washers. **DO NOT SUBSTITUTE ANY PARTS**

3. Now the M10 forged shoulder “eye” bolt should be installed in the top rear of the loudspeaker enclosure. (note, it may be necessary to remove the rear handle of the loudspeaker enclosure in order to mount the M10 eye bolt).

4. The loudspeaker may now be placed on the pole bracket (see figure 2).

**USE EXTREME CAUTION!** The loudspeaker is heavy and it is likely that the desired mounting location is high in the air. This process should never be attempted by a single person.

**TWO PEOPLE ARE REQUIRED TO MOUNT THE LOUDSPEAKER ENCLOSURE TO THE POLE AND POLE MOUNT ASSEMBLY EX!** (Safety harnesses should always be worn when working from an elevated platform)

First insert the M12 bolt into the pivot point and secure but do not fully tighten using the supplied M12 nylon insert nut.

Now the enclosure may be set at its desired down tilt. The Pole Mount System EX allows the loudspeaker to be oriented from a 0 degree down tilt to a maximum down tilt of 35 degrees.

**UNDER NO CIRCUMSTANCES SHOULD THE LOUDSPEAKER DOWN TILT EXCEED 35 DEGREES FROM VERTICAL!**

5. Now the Safety Link must be installed.

**INSTALLING THE POLE MOUNT SYSTEM EX WITHOUT THE SAFETY LINK IS NOT ALLOWED!**

The Safety Link (see figure 3) consists of two stainless steel quick links, a stainless steel turnbuckle, and several links of stainless steel chain.

**DO NOT SUBSTITUTE ANY PART OF THIS SAFETY LINK ASSEMBLY!**

The Safety Link should be tightened by rotating the turnbuckle until there is tension on the Safety Link assembly. Do not over tighten. The purpose of the Safety Link is to slightly remove tension from the main Pole Mount System EX tilting bracket at the bottom of the assembly. The Safety Link functions as both a safety and as a load bearing assembly.

The Safety Link should be assembled as shown in Figure 3. Make sure to use the appropriate number of chain links to insure proper connection between the Pole Mount System EX and the specific One Systems enclosure.

Figure 5 shows the loudspeaker assembly and Safety Link in a 0 degrees vertical orientation.

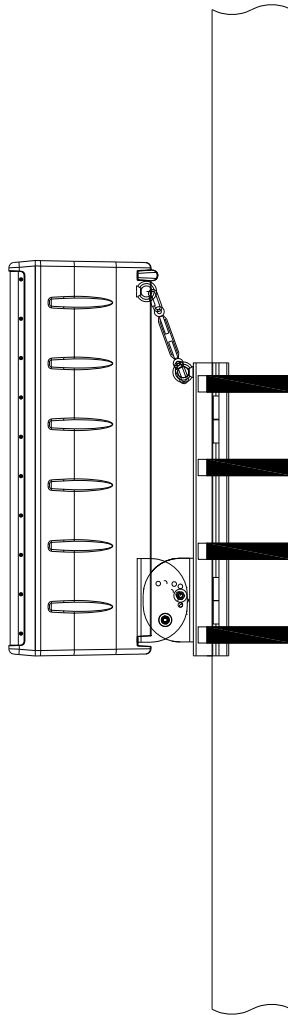

Figure 5.

Figure 6 is an enlarged view of the Safety Link assembly configured for a 0 degree vertical down tilt angle.

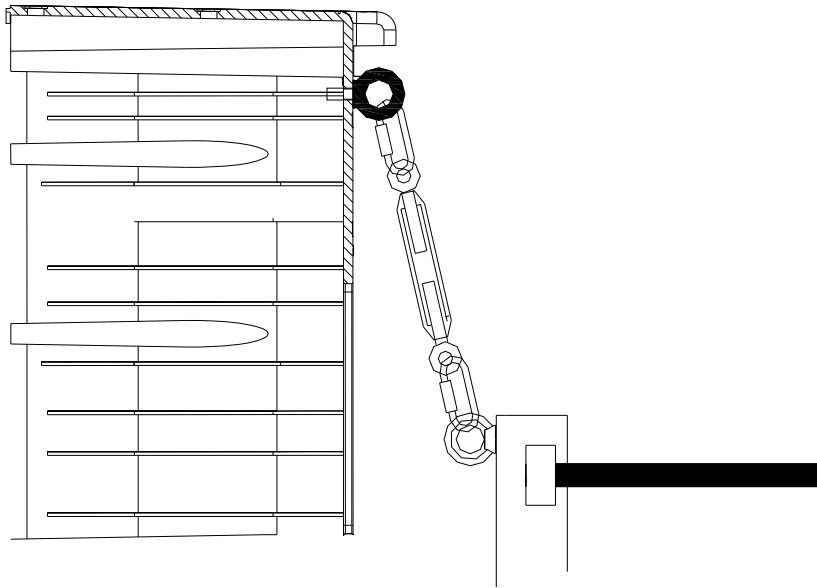

Figure 6.

Warning, if the turnbuckle assembly is turned and the loudspeaker enclosure angle begins to change (if the down tilt angle begins to move toward 0 degrees vertical then the turnbuckle has been **OVER TIGHTENED**. Turn the turnbuckle until the down tilt angle is set by the M10 thru bolt on the pole bracket.

Angles other than 0 degrees from vertical require the stainless steel chain links to be inserted as shown in Figures 7 and 8.

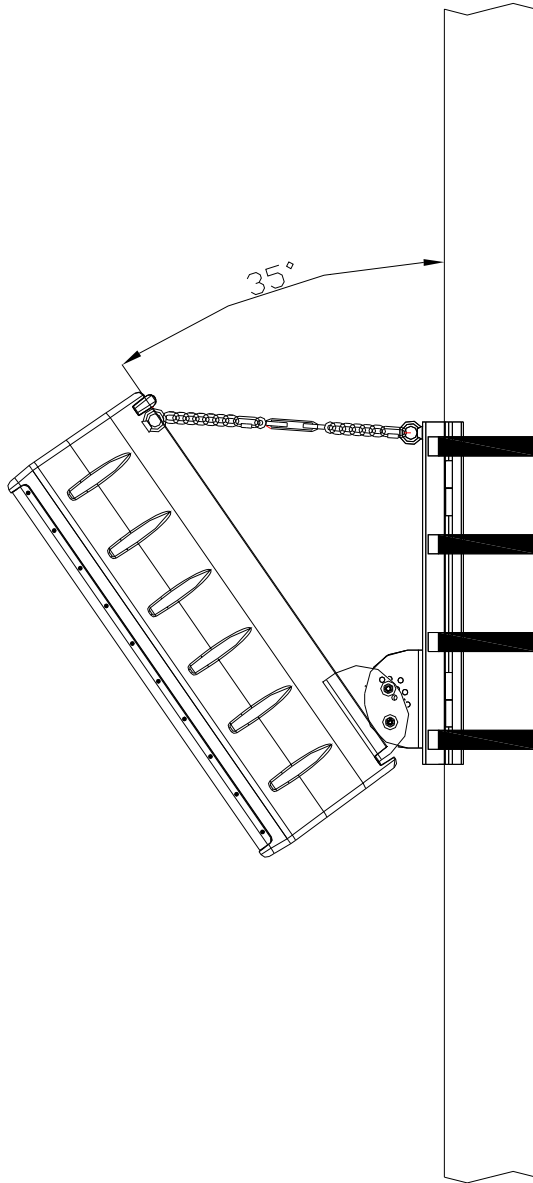

Figure 7.

Figure 7. represents the maximum down tilt angle of 35 degrees from vertical. Figure 8 is a close up view of the Safety Link assembly with the chain configured for this maximum angle. The lower quick link is positioned in various chain segments based on the desired degree of down tilt. The turnbuckle should be adjusted, as described in this section

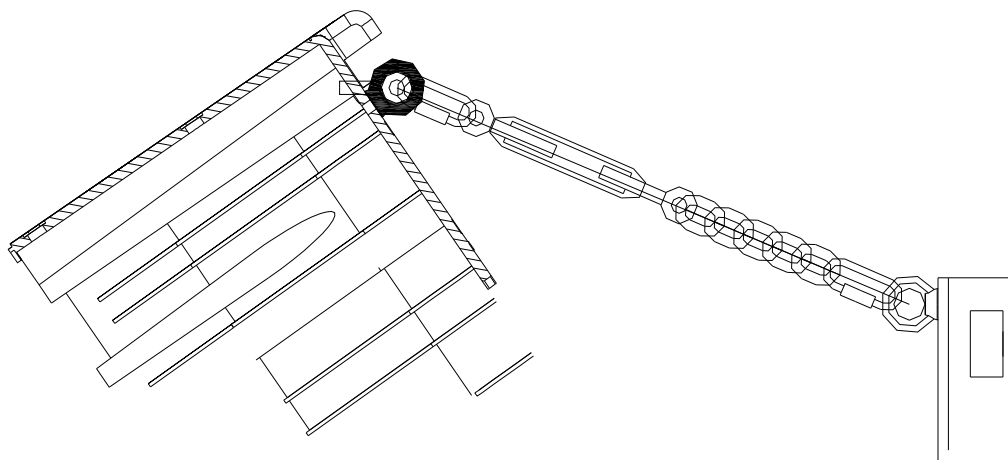

Figure 8.

Figure 9 shows a close up view of the Safety Link with one of the chain links moved to allow for an angle of less than the 35 degree max shown in Figure 8.

In any position, the turnbuckle must be adjusted to allow the proper amount of tension on the Safety Link. The safety link should never pull the loudspeaker up towards vertical. The link should be set in order to eliminate loose chain links only!

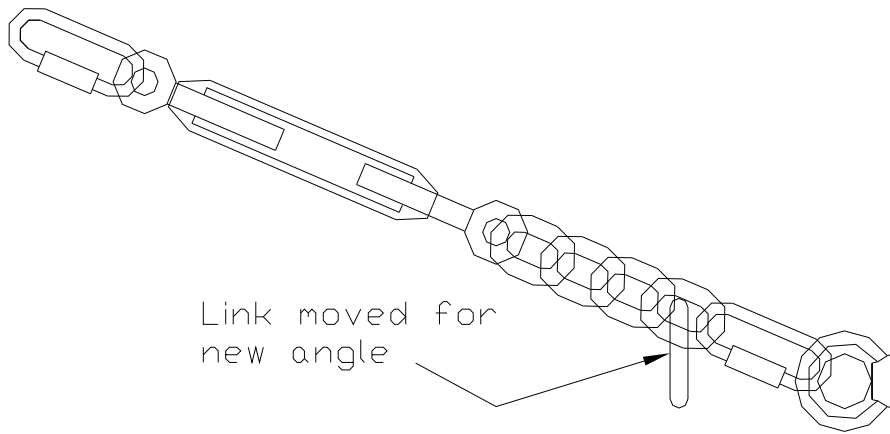

Figure 9.

## APPENDIX 1

### ( Projected Area Values)

The values below should be supplied to the specific pole manufacturer for safety calculations. These values were determined by adding the projected areas of the high frequency horns, the woofer cones and ports to the cross sectional area of the front of each enclosure listed below.

212IM ..... 804 in<sup>2</sup> (550,000 mm<sup>2</sup>)

312CIM..... 804 in<sup>2</sup> (550,000mm<sup>2</sup>)

Cross Field Array..... 2,708in<sup>2</sup> (1,750,000mm<sup>2</sup>)



**ONE SYSTEMS®**

**One Systems USA, Inc.** \* 6204 Gardendale Dr. \* Nashville, TN 37215

**One Systems Group Co. Ltd.** \* European Division \* Mittelsmoorer Strasse 12 \* 28879 Grassberg German

**One Systems Global Co., Ltd.** \* 87/114 Modern Town 15<sup>th</sup> Floor \* Sukhumvit 63, Ekkamai Soi 3, Klongtoey, Bangkok, 1010 Thailand