



ONE SYSTEMS HARSH WEATHER KIT

All One Systems™ loudspeaker systems are designed for use in permanently installed direct weather applications. The IM Series enclosures are ideally suited for extreme environments. The use of high weather-ability injection molded resin enclosures, stainless steel three layer grill assemblies and stainless steel internal rigging components insures high reliability and long service life in direct weather outdoor environments.

One Systems recognizes that marine environments present particular challenges due to high concentrations of air borne corrosive salt. Although grades of stainless steel have existed for years that are very tolerant of these high salt exposure conditions, certain internal loudspeaker components, particularly the soft steel components associated with the low frequency and high frequency transducer magnetic structures, are susceptible to corrosive activity, regardless of the associated protective coating technology.

Almost all professional audio transducer systems are designed as “vented” enclosures. Vented enclosure designs offer lower distortion in the last octave of rated operation and additional low frequency output, hence their widespread use in professional applications. The vented enclosure design, unfortunately, offers an ideal path for high salt content air into the enclosure. This path allows the soft steel of the transducer magnetic circuits to be compromised.

In addition to the enclosure vents allowing an air path into the enclosure, the One Systems ET-60x40 high frequency horns also allow an air path into the enclosure through the two side wall holes in the horn. These holes act as an “acoustic short circuit” for the acoustic resonance found in all medium to high Q horns. This acoustic resonance acts to alter the time domain performance of the system. However, like the vents for low frequency tuning, these holes must be closed for applications where high salt content is found in the atmosphere. (A parametric filter in the 400Hz to 600Hz range can mitigate this time domain effect once the horn wall holes are closed)

One Systems offers a Harsh Weather Kit designed to allow our loudspeaker systems to be used in environments that present air-borne corrosive salt elements. These kits are available for One Systems IM series enclosures only! The following kits are available for selected One Systems enclosures:

HWK-1	112IM and 212IM
HWK-2	212CIM
HWK-3	108IM
HWK-4	208CIM

The kits contain the necessary vent plugs (and high frequency horns, where applicable) to convert the loudspeaker systems into “closed” box designs.

If the 112IM or 108IM require the 105x60 horn for acoustic coverage, then the horn included (the ET-60x40 or ETS 60x40) in the HWK is not used, and only the vent plugs should be used. (The ET-105x60 and the ETS-105x60 do not employ the side wall holes as they are low Q designs and the column of air bounded by the horn walls is not resonant in a practical sense)

The 212CIM and 208CIM are coaxial high frequency designs and only require the low frequency enclosure vents to be plugged. **NOTE: The One Systems 212IM-L line array is a closed box by design and does not require a harsh weather kit!**

Figure 1 is an example of the location of the vent plugs in a One Systems 112IM

PROCEDURE

1. Remove the grill assembly from the enclosure
2. Remove the high frequency horn from the enclosure
 1. NOTE: This step applies only if the installed high frequency horn is either an ET-60x40 or an ETS-60x40
 2. Disconnect the compression driver from the high frequency horn (see note above, this step may not be necessary). Note the driver wiring polarity and insure the same polarity is observed when reconnecting the driver.
 3. Connect the compression driver to the ET-60x40 (or ETS-60x40) and re-install the high frequency horn in the enclosure.
4. Install the vent plugs in ALL enclosure vents.
5. Re-install the grill assembly on the enclosure.

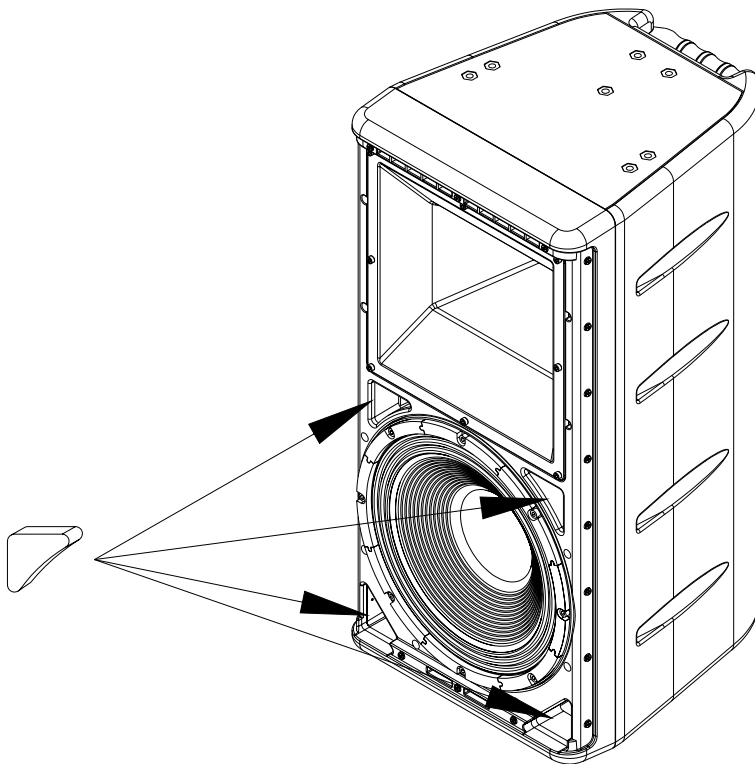

Figure 1