



POLE MOUNT MINI INSTALLATION (Amended March 14, 2011)

The Pole Mount Mini is an easy to install and flexible system designed to allow ONE SYSTEMS loudspeaker systems to be mounted to pole structures. The only products approved for use with the Pole Mount System are the 103IM and 106IM or transformer variants of the 103IM or 106IM.

NO OTHER LOUDSPEAKERS SHOULD BE SUBSTITUTED!

The following actions **MUST** be performed **PRIOR** to beginning the installation of the Pole Mount System:

1. This installation guide must be completely read and understood.
2. The instruction manual “Rigging and Suspension of ONE SYSTEMS Products” must be read and understood. This instruction manual is available at www.ONESYSTEMS.com in the “Education” section of the web site.
3. The manufacturer of the pole **MUST** be consulted to verify the applicability of the Pole Mount Mini and ONE SYSTEMS loudspeaker to the specific pole.
4. The Pole Mount Mini and loudspeaker should be installed only by one experienced in the overhead suspension of items and familiar with the applicable local and national codes governing installation of these products and also governing the attachment of these products to the specific pole structure.

CAUTION: All structures outdoors are subjected to wind forces. These forces must be considered when suspending any product outdoors. It is necessary to know the “Effective Projected Area” (EPA) of the loudspeaker prior to installation of the loudspeaker and Pole Mount Mini. This data must be supplied to the pole manufacturer in order to determine safe operation conditions for the loudspeaker and Pole Mount Mini when mounted to a specific pole. See Appendix 1 of this installation manual for “Equivalent Projected Area (EPA) values for the 103IM and 106IM. These values may also be found on the ONE SYSTEMS web site at www.ONESYSTEMS.com.

INSTALLATION

The Pole Mount Mini consists of two parts: the pole bracket assembly, and the forged shoulder eye bolts and supplied cable assembly. The pole bracket is shown in Figure 1. The bracket shown in figure 1 is designed for use on circular poles with diameters of 4 inches (101.6mm) or larger. The Pole Mount Mini may also be used on square or rectangular pole faces of 3.75 inches (92mm). Round pole diameters smaller than 4 inches or square/rectangular face widths of 3.75 must not be used.

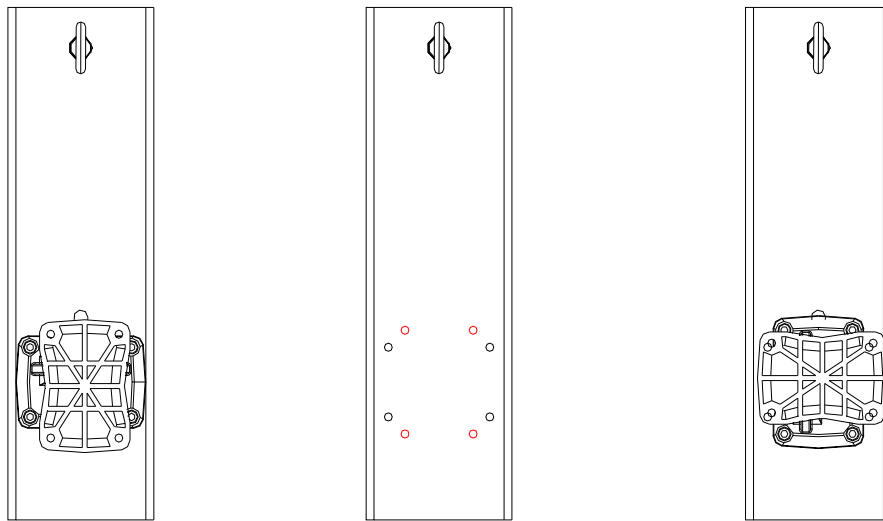

Figure 1

NOTE!

1. The PT-10 pan and tilt bracket may be oriented in two ways on the Pole Mount Mini back plate. The orientation on the left is used when the 106IM is to be mounted. Using this configuration will result in the 106IM being oriented in a vertical orientation. The PT-10 is mounted using the 4 black holes shown in the center image above. The red holes, also shown in the center image, should be used when a 103IM is mounted and the desired orientation of the enclosure is vertical.

NOTE: It is best to preset the desired pan and tilt angles PRIOR to mounting the Pole Mount Mini on a pole. (Step 2 below offers details) Mount the pole mount section (see figure 1) of the bracket to the pole at the desired height on the pole. The bracket is mounted to the pole using BAND-IT stainless steel bands. **DO NOT SUBSTITUTE** bands of other material or other widths! There are three locations on the pole bracket for bands.

IMPORTANT: ALL THREE BAND LOCATIONS MUST BE USED.

Figure 2 illustrates the locations for the stainless steel band clamps.

IMPORTANT: It is **REQUIRED** that each of the three bands be double wrapped. Double wrapping will insure a strong and secure mounting of the bracket to the pole. The stainless steel banding materials should be as follows:

BAND-IT	# C206R9 stainless steel bands
BAND-IT	# C25699 buckles
BAND-IT	# C00169 tensioning tool

The stainless steel band is Type 201SS 0.030 inches (0.762mm) thick and 0.750 inches (19mm) wide.

WARNING: Do NOT substitute banding materials or banding dimensions.

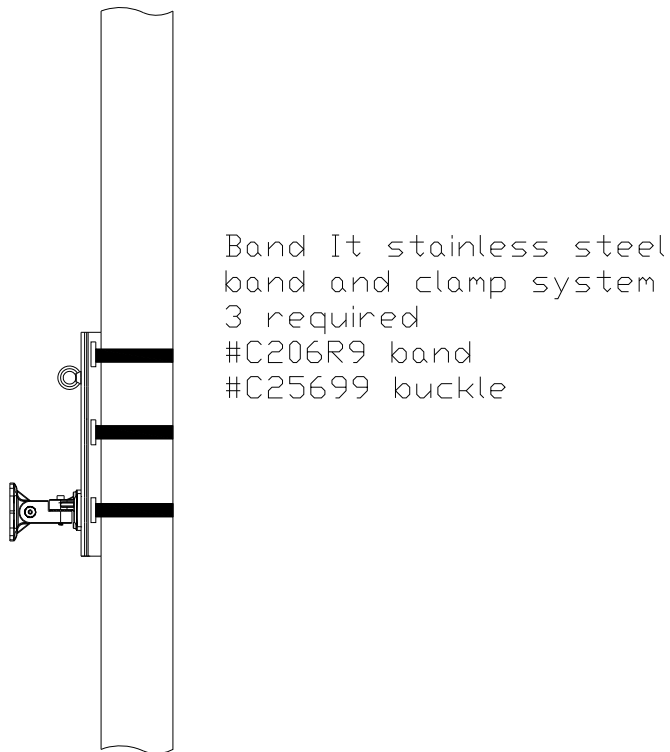

Figure 2.

Installation instructions from BAND-IT should be followed exactly. Operating instructions are supplied with the tensioning tool. (All BAND-IT parts and tools purchased separately. These parts and tools are not supplied by ONE SYSTEMS).

The stainless steel banding material, buckles and tensioning tools are available from the following locations (or through distributors recommended by these locations):

BAND-IT IDEX, Inc.
4799 Dahlia St.
Denver Colorado 80216
USA
1-800-525-0758

FELIX PONCE
Calle Ignacio Zaragonza No. 8
Colonia Ahuehuetes Atizapan 52953
Edo. de Mexico
(52) 555825 8502

BAND-IT Company Limited
Speedwell Industrial Estate
Stavely, Nr. Chesterfield
Derbyshire, S43 3PF England
Home Sales (44) 1246-479479
Export Sales (44) 1246 479480

BAND-IT Clamps (ASIA) Pte. Ltd.
11 Second Chin Bee Road
Singapore 618777
65-62658853

BAND-IT Shanghai Sales Office
207 room
Wanbao International Business Centre
660# Xinhua Road
Shanghai, China 200052
021-62826348-308

2. Attach the appropriate eye bolt to the enclosure. The eye bolt is attached to the rear (top rear) of the 106IM. The eye bolt is attached to the top of the 103IM. There are two eye bolts supplied. One is an M8 eyebolt for use on the 106IM. The second eye bolt is an M5 and is for use on a 103IM. Use the eyebolt that mates with the specific loudspeaker being mounted to the Pole Mount Mini.

Next, the pan and tilt angles of the PT-10 bracket should be set.

The pan and tilt function allows pan and tilt angles in 10 degree increments.

Note: Two different center pieces are supplied for the PT-10 bracket that will accommodate 20 degree increments, with each center piece incremented by 10 degrees to allow for the 10 degree total pan and tilt adjustment. Select the proper center piece that provides the correct aiming angles. See the illustration below for details on the center piece of the PT-10.

NOTE: Do Not use both center pieces!

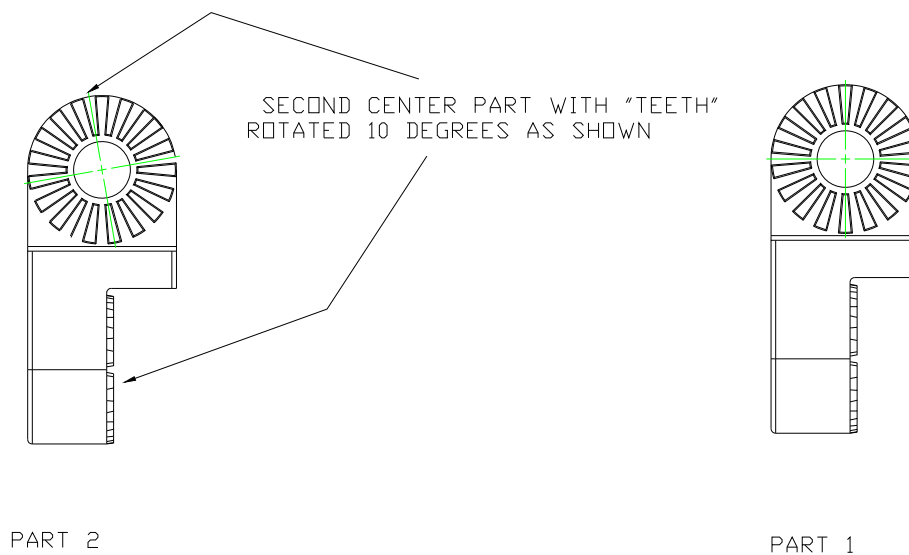

Now the loudspeaker (103IM or 106IM) should be mounted to the loudspeaker bracket (PT-10) using the supplied stainless steel bolts and washers (M5). It is recommended that the desired pan and tilt angles of the loudspeaker be set on the PT-10 portion of the assembly prior to mounting the loudspeaker.

The instructions for the PT-10 portion of the Pole Mount Mini are also included and should be referred to when setting the pan and tilt angles.

3. The Pole Mount Mini is supplied with a forged shoulder eye bolt. This bolt is designed to be used with a secondary cable assembly. This cable assembly must be configured **AFTER** the enclosure is mounted on the PT-10 portion of the Pole Mount Mini. An M8 eye bolt is supplied to allow the 106IM enclosure to be fitted with the supplied cable assembly. An M5 eye bolt is supplied to allow the 103IM to be fitted with the supplied cable assembly.

INSTALLING THE POLE MOUNT SYSTEM WITHOUT THE CABLE ASSEMBLY IS NOT ALLOWED!

NOTE: Review all remaining sections before configuring the cable assembly!

4. Configuration of the supplied cable parts (cable, thimbles and compression sleeves).

DO NOT PRE ASSEMBLE THE CABLE.

The cable assembly **MUST** be assembled **AFTER** the enclosure is mounted to the bracket and the bracket is suspended. See Figure 5 for detail of the finished assembly.

The cable assembly consists of a length of 1/16 inch stainless steel wire rope, two ¼ inch stainless steel thimbles, and two oval sleeves. The ¼ inch thimbles must be spread to fit over each of the eyebolts. The wire rope should be configured and the sleeves crimped AFTER the thimbles have been installed around the eyebolts. The cable parts are shown in figure 3. The length of the wire rope is determined by the pan and tilt angles of the enclosure.



Figure 3

Figure 3 is a photograph of the wire rope section and one of the thimbles as well as one of the oval sleeves. Make sure that the oval sleeve is crimped using the proper crimping tool. A close view of the assembly is shown in Figure 5.

NOTE: A special crimping tool is required for stainless steel compression sleeves. The use of a tool that is not approved for use with stainless steel compression sleeves will result in reduced ratings for the wire rope assembly.

The proper tool to use is produced by:

**Loos and Company, Cableware Division.
901 Industrial Blvd.
Naples, FL 34104-3715
1-800-321-5667**

The correct tool is:
No. 0-3/64SC

This tool is designed for use with stainless steel compression sleeves. This tool or the equivalent must be used when swaging the compression sleeves.

When crimping stainless steel compression sleeves you MUST use one size smaller diameter on the crimping tool. For 1/16" sleeves and cable you MUST use a 3/64" crimp set.

The cable assembly requires the use of a compression tool to securely fit the oval sleeves. One Systems does not supply this compression tool. The assembly of the cable must be done by one who is experienced and competent in wire rope assembly and is familiar with the operation of the required tools.

See Figures 4 and 5 for details of the proper cable assembly to the enclosure and bracket. Figure 4 shows both the 103IM and 106IM loudspeakers mounted to the Pole Mount Mini bracket with the cable assemblies included. The length of the wire rope should be adjusted so that there is very mild tension on the cable assembly. The cable assembly should not be loose or have any slack but the cable assembly should not be so tight as to begin pulling the top of the enclosure back toward vertical. The length of the wire rope is determined by the tilt and pan angles of the enclosure.

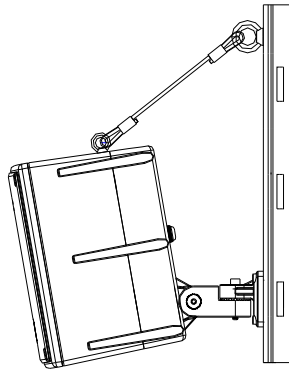

103IM and Pole Mount Mini

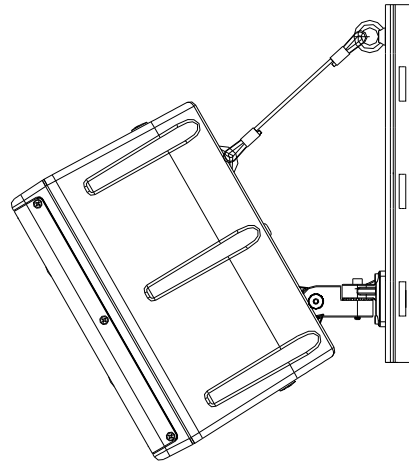

106IM and Pole Mount Mini

Figure 4

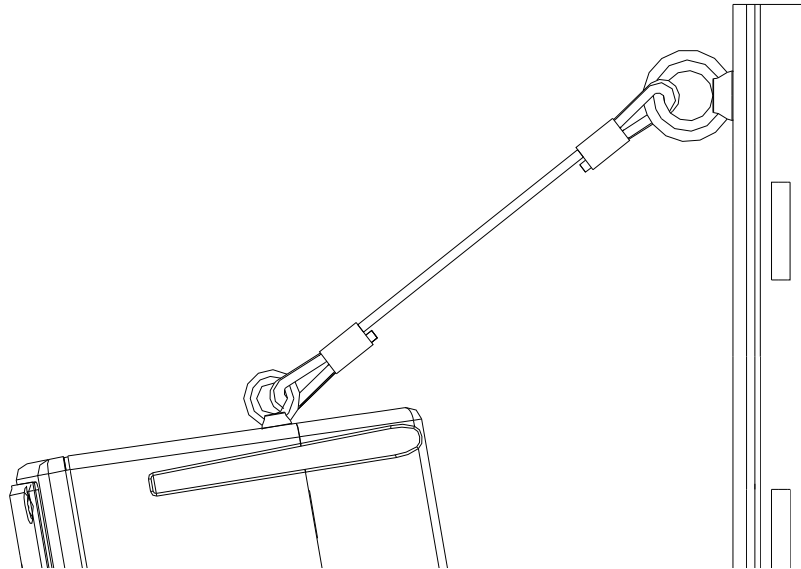

Figure 5

Figure 5 is a close up view of the wire rope assembly. One end is connected to the M8 eyebolt on the Pole Mount Mini and the other end to the eyebolt mounted to the enclosure (103IM shown in Figure 5, for the 108IM the eyebolt is located on the rear of the enclosure near the top).

Note: The ¼ inch thimbles must be spread slightly to fit over the eyebolts and then recompressed.

APPENDIX 1

(Projected Area Values)

The values below should be supplied to the specific pole manufacturer for safety calculations. These values were determined by adding the projected areas of the high frequency horns, the woofer cones and ports to the cross sectional area of the front of each enclosure listed below.

103IM 60 in² (38,709 mm²)

106IM..... 90 in² (58,064mm²)